

# Quiet Science

Sound Insulation and Noise Control  
Cutting Decibels

By Dave Gerr, CEng FRINA © 2008 Dave Gerr

I've been on boats that were so loud—from engine noise alone—I couldn't hear any conversation at less than a shout, and that from no more than a few feet away. When sitting quietly at anchor, many approaching power craft announce their rumbling, buzzing presence from a mile off or more. Tests have conclusively proved that noise of this sort leads to fatigue, ear damage, and even elevated blood pressure. What's more, when you're aboard such a vessels you

ble, it would be a complex undertaking. There is no excuse, though, for not designing and building a boat with sufficient sound insulation so that noise in the cabin was at comfortable conversational levels or less—something around 75 decibels (dB) or lower. Whether designing, building, modifying, repowering, or refitting, you should be working on noise control as a fundamental consideration from the early stages.

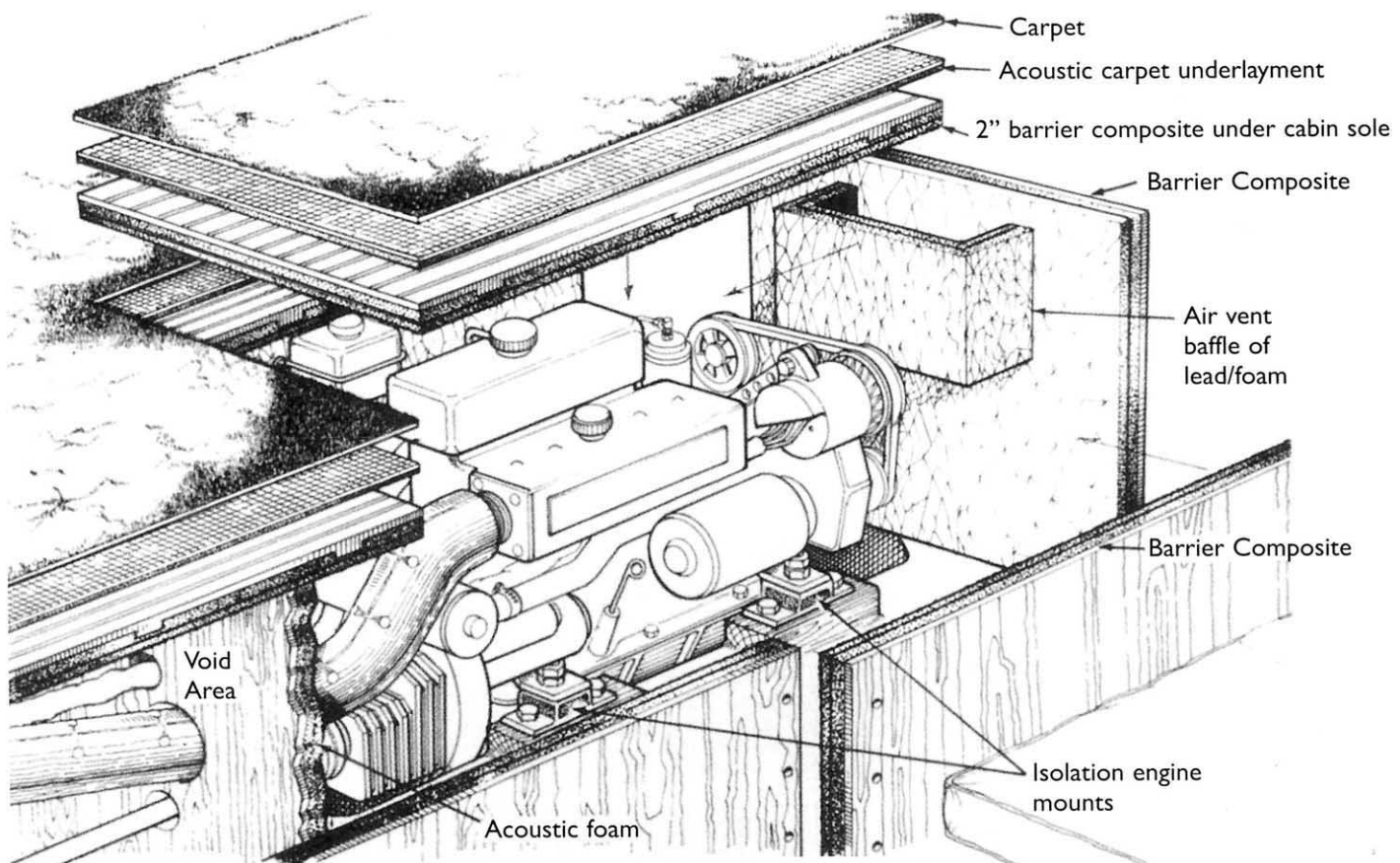

Typical Engine Compartment Insulation—Small to Midsize Boat

Courtesy Soundown

can't hear the waves, the birds, the fish jumping, or any of the other fine things you're supposedly on the water for in the first place. What I'd love to see (and to own) would be a "stealth" boat. I'd like to be able to whiz by at 30 knots—the only audible noise, water whooshing along the hull.

Though a true "stealth" boat is theoretically possi-

## Sealing the Leaks

So, how can you design your *Rickety Racket* to be a *Stealthy Streak*? The first thing is to make the engine compartment airtight (except, **most important**, for the engine air vents themselves). Study every inch of the engine box and/or the bulkheads and the sole over the engine compartment. Check for holes or gaps. Plan to close every single

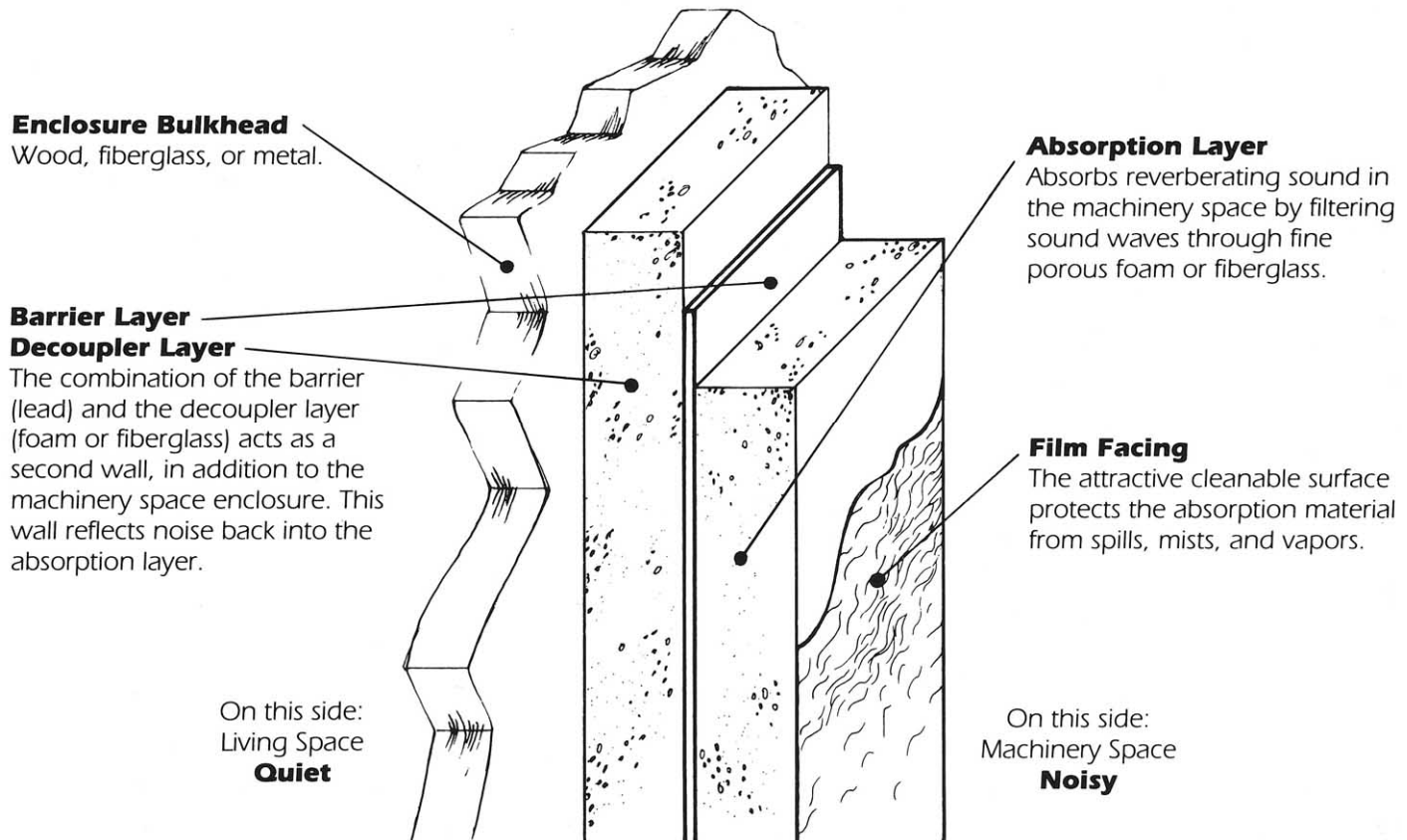

## Mass Barrier and Insulation Layers

Courtesy Soundown

hole tight. Spec neoprene ring grommets to seal around all hoses, pipes, and wires in bulkheads. Or, use fiberglass insulation jammed in holes and taped or clamped firmly in place. At all the engine hatches, install neoprene gaskets and clamp-action latches. These steps alone will yield a noticeable noise reduction.

### Padding the Box and Mass Damping/Decoupling

The next step is to apply sound insulation to the inside of the engine box or to the inside of the engine compartment. Sound insulation comes in several flavors. There's foam, and fiberglass, and there's insulation with lead sheeting buried in it, or with similar heavy-mass sheets of other materials. The lead (or other heavy-mass sheet) isn't to protect you from some obscure nuclear mishap but to damp out the vibrating energy in noise. Engine noise causes the foam or fiberglass to vibrate. Even though the foam deadens the sound, it does vibrate a bit itself, which in turn transmits some noise, particularly at low frequencies. If, however, the sound has to vibrate the mass of a dense sheet, much more energy is used up than

with foam or fiberglass alone—less noise is left to transmit. Engineers—in their usual manner—have coined a phrase to describe all this: “mass damping.”

The mass damping sheet (lead or heavy vinyl) also decouples the vibration/noise in the inside of the engine compartment from the outside and reflects back noise as well. Thus, a sheet of fiberglass or foam insulation facing into the engine compartment absorbs some noise. A mass damping sheet outside of this absorbs low frequency vibration and reflects back sound. A final layer of fiberglass or foam insulation, outside the mass damping sheet, is now decoupled from the vibrations inside the compartment. In other words, the mass-damping sheet and inside insulation “float” on the outside insulation layer. This is the most effective combination for cutting noise.

Most average boats under 45 feet, or so, use 3 inches of insulation. A good combination is 2 inches of fiberglass or foam inside, a mass damping sheet, and an outside layer of 1-inch insula-

tion. Premanufactured sheets like this are available for easy one-piece installation. Increase to 4 inches total if you can, but a bare 2 inches will be *well* worthwhile if that's all you have room for.

### Mass Damping Sheets and Other Mass Damping

In the old days, the only common material for mass damping was sheet lead. It was usually specified as 1 pound per square foot or 2 pound per square foot, or 1/32-in. thick lead sheet (which is about 1.85 pounds per square foot).

Lead is still one of the best materials in terms of mass damping, and it doesn't burn, but it is expensive and has environmental drawbacks. Over the last few decades, vinyl mass damping sheets in 1 to 2 pound per square foot density have become widely available and are very effective. These vinyl mass damping sheets are somewhat thicker than comparable lead (though this is a very slight difference). The vinyl can burn however; though, it is not highly flammable like some insulation foams. One pound mass-damping sheet is common but 1.8 to 2 pound per square foot is noticeably more effective. The drawback . . . extra weight, obviously. Big boats, over 50 feet, should use the 1.8 to 2 pound sheet whenever possible.

Mass damping can also be used directly on critical structures. A useful method of reducing engine vibration transmitted to the hull, for instance, is to bolt lead weights to the engine beds themselves (beds of any construction—wood, fiberglass, or metal) to help absorb vibration. Weights equal to about 10% to 12% of the combined weight of the engine and the transmission are about right.

The drawback is obvious—the added weight itself. This isn't too much of an issue—if allowed for in initial design—on displacement boats but it is generally excessive weight for most planing hulls.

Although foam insulation is acceptable for pleasure craft and can provide slightly better sound deadening, I prefer fiberglass insulation on boats. Foam burns, fiberglass doesn't. Indeed, fiberglass

### Defining The Decibel?

The term “decibel” (dB) is a unit for measuring the loudness of a sound or the strength of a signal (say an electric signal). For our purposes here, we're only interested in sound. The “bel” in decibel is in honor of Alexander Graham Bell, the inventor of the telephone (among other things). Decibels (dB are actually a ratio), specifically the logarithm of the ratio of two sound levels. One Bel (a term not commonly used) is when the output noise is ten times greater than the input noise on a transmitting device. A decibel is a tenth of a Bel. This is where the “deci” in “decibel” comes from.

You can see from the table that a quiet room a night is about 20 to 30 dB, while a noisy engine room is about 100 to 120 dB. One dB is about the threshold of hearing. Since decibels are a ratio there has to be a standard or reference sound level or pressure (pressure wave) and it is commonly 0.0002 microbars of pressure. (A bar is one atmosphere or 14.7 psi.) This is the threshold of hearing—a barely perceptible sound for a young person with perfect hearing in an otherwise exceptionally quiet environment.

Sound (noise) is a difficult thing to quantify accurately because it is something you perceive. Simply measuring the precise energy in the sound pressure waves doesn't translate exactly into the amount of “loudness” or “softness” you distinguish in a sound. People respond to or hear sounds differently at high frequency, mid-range frequency, and low frequency. Accordingly, sound is usually measured with decibel meters based on a standard scale called the “A scale.” This scale accounts not only the energy in the pressure waves but the sound's frequencies to give decibel readings that relate more closely to how you perceive sound. Levels from such meters are properly in dBA—the A being for the A scale.

Note that decibels (dB) are logarithmic units (log to the base 10) and so the decibel scale (from zero to 200) covers an incredible range of power. Twenty dB represents 100 times the power as 0 dB (0.0002 microbars of pressure), while 40 dB is 10,000 times the power of 0 dB, and so on. In terms of perceived loudness, experiment has found that an increase of 10 dB is about equal to what most people would say is doubling the loudness.



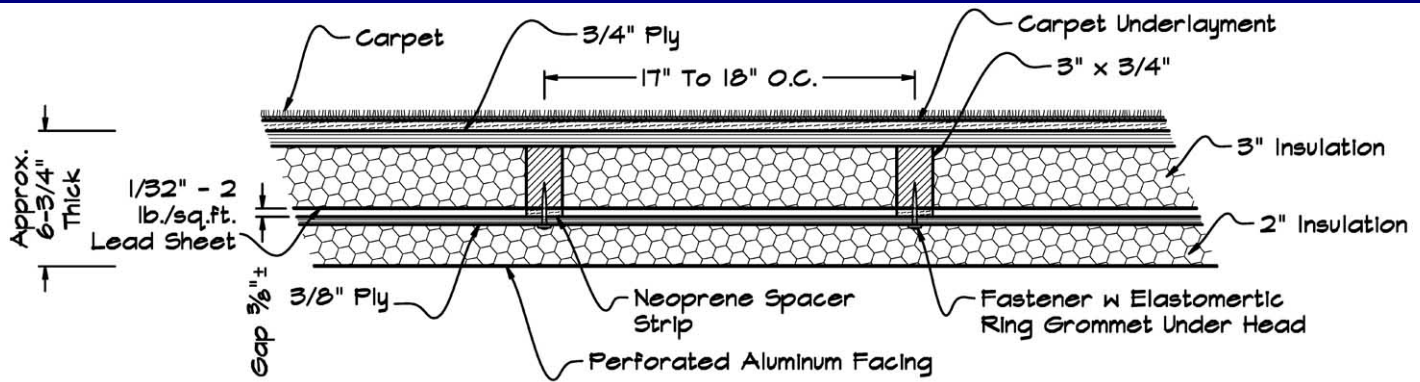

**Engine Compartment Insulation Big Boat—Wood Construction**

Dave Gerr

sound insulation can actually help delay the spread of a fire, giving you a bit more time to put it out.

**Big-Boat Engine Compartment Insulation**

On vessels over 50 feet, or so, you can and should consider thicker and more sophisticated insulation than above. The drawings show insulation for the underside of an engine compartment, with a cabin above, it on a larger boat. Note that there is 3 inches of foam or fiberglass insulation directly under the cabin sole. Beneath that, is the 2 pound (or 1/32-in. thick lead) mass damping sheet (lead or vinyl). Then, note the air gap. This is even more complete decoupling than with the interior insulation glued directly to the mass-damping sheet. Below this gap is a layer of 3/8-in. plywood which supports the interior insulation layer 2 inches thick.

It's important to incorporate the soft neoprene spacers at the fasteners between the inside insulation structure and the outer insulation structure. See also that the underside of the fasteners are further isolated with elastomeric (soft) ring grommets. It is critical that vibration from the interior

insulation structure not be directly transmitted to the exterior insulation layer. The maximizes the decoupling and so the sound reduction.

The same construction described here can be used on the fore-n-aft bulkheads of the engine compartment for really optimal quieting effect.

**Db Plywood**

In all wood panels around the engine compartment, I usually specify dB-ply panels from Greenwood Products ([www.greenwoodproducts.com](http://www.greenwoodproducts.com)). This is plywood with a mass damping sheet embedded in it. Though not required, it is amazingly effective a deadening the transmission of sound, and makes the boat that much quieter. Though the drawings here just call for plywood (which is acceptable), I'd use dB-ply.

**Cabin-Space Sound Insulation**

As good as any engine-compartment insulation may be, some sound will radiate out into the cabin spaces. If the cabin is all hard surfaces, this sound will echo and reverberate. To make things quieter still, use carpet with sound-deadening carpet underlay on the cabin sole, and a sound dead-

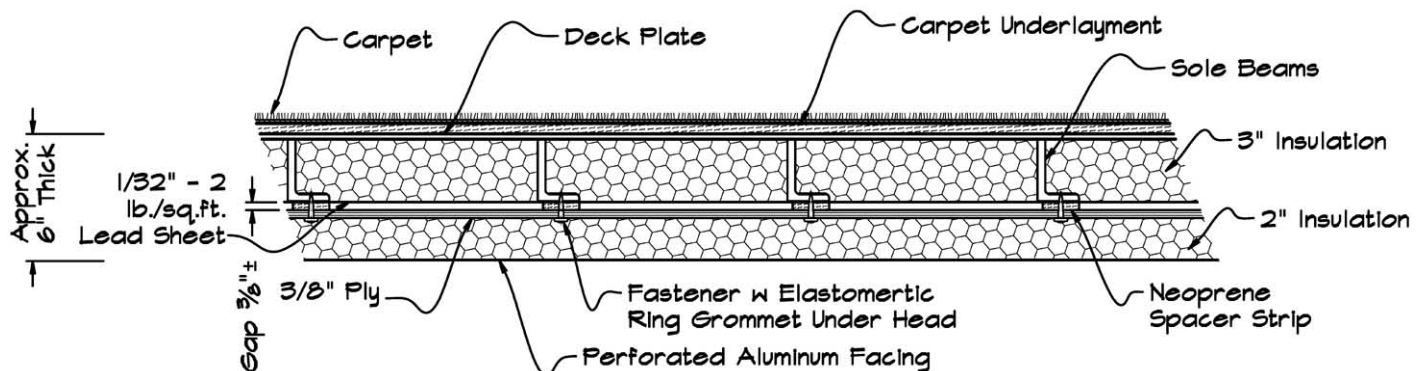

**Engine Compartment Insulation Big Boat—Metal Construction**

Dave Gerr

ening headliner on the overhead. The combination dramatically reduces noise in any cabin space.

**The Ideal Decibels**

So what target in quiet (low noise) should you strive for in decibels (dB)? There isn't a precise answer, but you can refer to the Decibel (dB) Levels table for guidance. For most boats, you should strive to achieve cabin noise, at cruising speed, under 80 dB. A really fine yacht, with optimum sound control throughout should achieve around 65 to 70 dB at normal cruise and around 65 at low cruise. In the real world, it's hard to get much lower than this, but great attention to detail could bring cabin noise down to close to 55 dB. This would be perceived as nearly silent running and is no mean feat.

At anchor, generator noise is much more noticeable. (There isn't the surrounding or masking noise of wind and motion through the water.) Anything over 65 dB from the gen set is really too high. You should be able to get down to 45 to 50 dB in the cabin, a bit lower on a large boat with excellent sound control.

**Clean Insulation**

Install insulation that comes with a mylar, vinyl or similar smooth easy-clean surface on its exposed face. Insulation without this facing gets grime and oil soaked quickly. An even better alternative is surfacing the exposed side of the insulation with perforated aluminum sheet. This makes a relatively abrasion resistant surface that is easy to wipe clean. Avoid using aluminum wire mesh screen or fence material. This is almost impossible to clean and actually catches dirt.

**Fastening Insulation**

Adhesive sheets or glue are available to attach the insulation to the overhead, bulkheads, or the hull sides. In general, I recommend against this. It's better to be able to remove the insulation

quickly and cleanly for maintenance and repairs. The insulation can be fastened with long screws and "ceiling" rosettes or with pin fasteners—see illustrations next page. These not only allow rapid removal of the insulation, but are quicker and neater than gluing the sheets in place.

Decibel (dB) Levels			
	dB	Cruising Under Power	Generator At Anchor
Rocket Booster	200		
	190		
	180		
	170		
Jet Aircraft - Full Power	160		
	150		
	140		
	130		
Chain Saw - PAIN THRESHOLD	120	Engine Room	
Thunder	110	↑	
Chain Saw At 3 Feet	100	Engine Room	
	95	Cabin - Loud	
City Traffic	90	↑	
	85	Cabin - Normal	
Jackhammer At 50 Feet	80	↑	
	75	Cabin - Normal	Loud
Inside Car At 55 mph	70	↑	↑
Room With Window Air/Conditioner	65	Cabin - Quiet	Normal
Normal Conversation	60	↑	↑
	55	Cabin - Silent	↑
	50		Normal
Hotel Room	45		Quiet
↑	40		Quiet/Silent
Hotel Room	35		↑
Quiet Home Bedroom At Night	30		Silent
↑ (Whisper)	25		
Quiet Home Bedroom At Night	20		
	15		
	10		
	5		
1 Db = Threshold Of Hearing	0		

**Padding the Walls (and Floors)**

Many boats take all the steps described so far, and no more than this—combined with a proper muffler—will dramatically reduce noise to comfortable levels. Still, your *Rickety Racket* won't be a true *Stealthy Streak*. What more can you do? First, line the inside of hull, in the engine compartment, with 1-inch to 2-inch sound insulation with

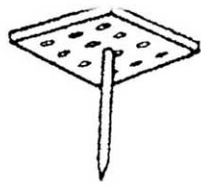

Install fastener with screws, nails, epoxy general purpose paste adhesive, etc.  
Do not use spray adhesive



Speed Washer

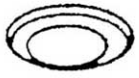

Domed Cap

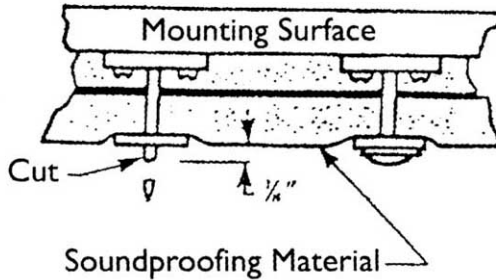

Soundproofing Material

### Pin Fastening

Courtesy Soundown

1- or 2-pound mass damping sheet. This prevents engine noise from transmitting through the hull sides into surrounding air and water and up to your ears. It also prevents engine noise from bouncing back and forth inside the hull.

Second, line the lower portion of the bilge with vinyl sound absorbing tiles or sheets. It's important not to run the standard fiberglass or foam sound insulation too far down into the bilge. Water, oils, and grease, will quickly make this a foul, dirty mess. At these low locations, you must use a smooth-surface plastic sheet material that won't absorb water or oil and that's easy to clean.

The area over the propeller will further benefit from the addition of glued-on mass damping tiles. These dramatically cut both transmitted vibration and direct propeller noise.

### Sound-Box Song Silence

An ultimate stealth trick is to add a sound box around *Rickety Racket's* engine. This is precisely like the sound boxes that come as optional equipment on many diesel generators. Usually, you won't have room to add a sound box on *Rickety Racket* unless it was designed to have one in the first place. Remember, **ALL** the sound box panels must remove **QUICKLY AND EASILY, AT AN INSTANT'S NOTICE**. If you have the space, however, you can make the box of aluminum angles bolted together to form the corners, with, say, 1/4-inch plywood sheets fastened to the angles with quick-release latches.

The inside of the panels, facing the engine, should be covered with 1- to 2-inch mass-damped/fiberglass insulation.

To ensure proper ventilation to the engine, the bottom 2 inches of the box should be open the full length of both sides. Further, the upper sides of each side panel, just below the upper corners, should have vents with baffles in front of them. A sound box will cut noise in the engine compartment by almost half, so all the other insulation (around the engine compartment proper) has less work to do, or can be more effective. Remember that fuel, water, and exhaust lines have to penetrate the sound box.

The whole arrangement takes careful thought and consultation with the manufacturer.

Though not common on main engines, sound boxes or enclosures are common (virtually standard) on generators and I always specify them.

### Quiet! Air Entering

Clearly the openings we can't seal at all are the engine-air intake and exhaust vents. These absolutely **must** have a **bare minimum clear** cross-section area equal to total engine horsepower divided by 3.3. If your *Rickety Racket* had twin 220-hp engines plus, say, a 5-kw generator (figure  $1.5 \times 5 \text{ kw} = 7.5$ , say, 8 hp) it would require 136 square inches of clear unobstructed duct opening ( $220 \text{ hp} \times 2 = 440 \text{ hp} + 8 \text{ hp} = 448 \text{ hp} \div 3.3 = 136 \text{ sq.in.}$ ). If sound baffles are built into the air vents, this number should be increased by at least 40 percent to 190 square inches.

Keeping this in mind, you can reduce engine

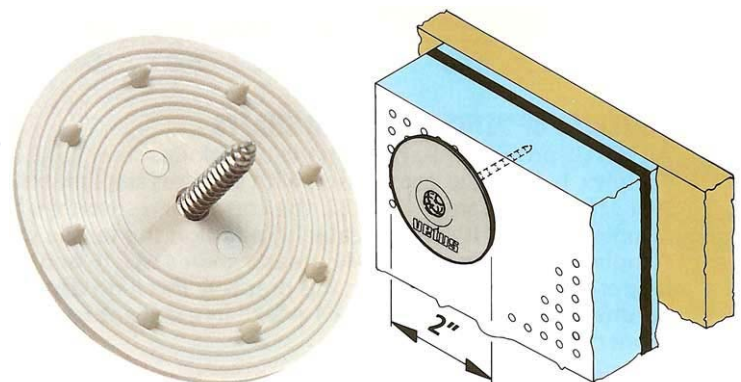

Ceiling Rose Fastening

Courtesy Vetus Den Ouden



noise still further by lining the inside of the air ducts with 1/2- to 1-inch thick insulation covered with a mylar protective easy-clean facing. Where possible, the outside of the ducts (inside the boat) should be covered with 1- to 2-inch mass-damped/insulation. Further, ideally, there should be a baffle before the vent exit that forces the air to travel around a 180 degree bend or to make U-turn. Both sides of the baffle should have the duct insulation on it. Remember though, that every part of the air intake, even every place around the baffle, has to have at least the minimum clear cross-section area. If, for example, *Rickety Racket*, had four engine vents, they should total 190 sq. in. so each should have 47.5 square inches clear area—in this case about 8-in. by 6-in.

All the air duct openings should be overboard, to direct noise away from the boat, but be very certain that water can't find it's way back in through these vents.

### Muffling the Muffler

Have we done all we can do to stamp out noise? Has *Rickety Racket* earned its name change to *Stealthy Streak*? No, not yet. First, we have to look at the exhaust. *Rickety Racket* has to have a proper muffler. Keep in mind, that the larger the muffler the more effective it is; use the largest size you can fit. Next, you can warp the muffler and the exhaust line with 1-inch fiberglass insulation. Wrapping the exhaust line with insulation is seldom done, but it doesn't cost much and reduces noise still more.

### Submarine Exhaust

Even better, you can install underwater exhaust. This, however, is a big project. There are a few production boats on the market fitted with underwater exhaust. They're difficult to design properly;

but, if they do work, not only do they shoot exhaust noise down into the water where you can't hear it, but they generate a mild supercharging effect from suction at cruising speeds. An underwater exhaust that worked well is the one I helped design for the *Cape Dory 40* (a pretty darn quiet boat). This system avoids the great pitfalls of underwater exhausts: too much back pressure at idle, and sucking exhaust gases into the propeller intake stream. Underwater exhaust installation is covered in detail in my new book, *Boat Mechanical Systems Handbook*.

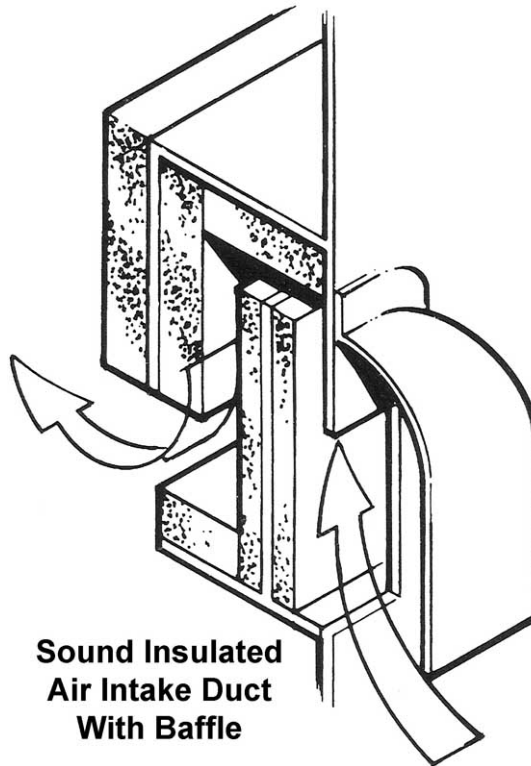

Sound Insulated  
Air Intake Duct  
With Baffle

Courtesy Halyard (Marine & Industrial) Ltd.

### Flexi-Mounts

There's still one very important source of noise to address—engine vibration. It's not possible to really separate noise and vibration. But noise as vibration can be transmitted to the hull through the engine mounts as well as through the propeller shaft. To eliminate this, the engine should be mounted on flexible engine mounts, with a flexible propeller-shaft coupling. It's VITAL that the engine mounts and the shaft coupling be properly matched. If the mounts allow more movement than the coupling can accept, the coupling can fail—big trouble!

### Vibrationless Drive?

The ultimate in engine isolation is the Aquadrive system readily available worldwide. Another similar system is PYI's Python Drive. The Aquadrive (or the Python Drive) comes with a true double CV-joint and with a built-in thrust bearing, and is equipped with matching very high-flexibility soft engine mounts. The system virtually eliminates engine vibration transmitted to the hull, and—at the same time—it greatly eases shaft-alignment problems. The Aquadrive takes up more room than a standard coupling and is more expensive. Usually, it has to be designed in from scratch; however, if you have a

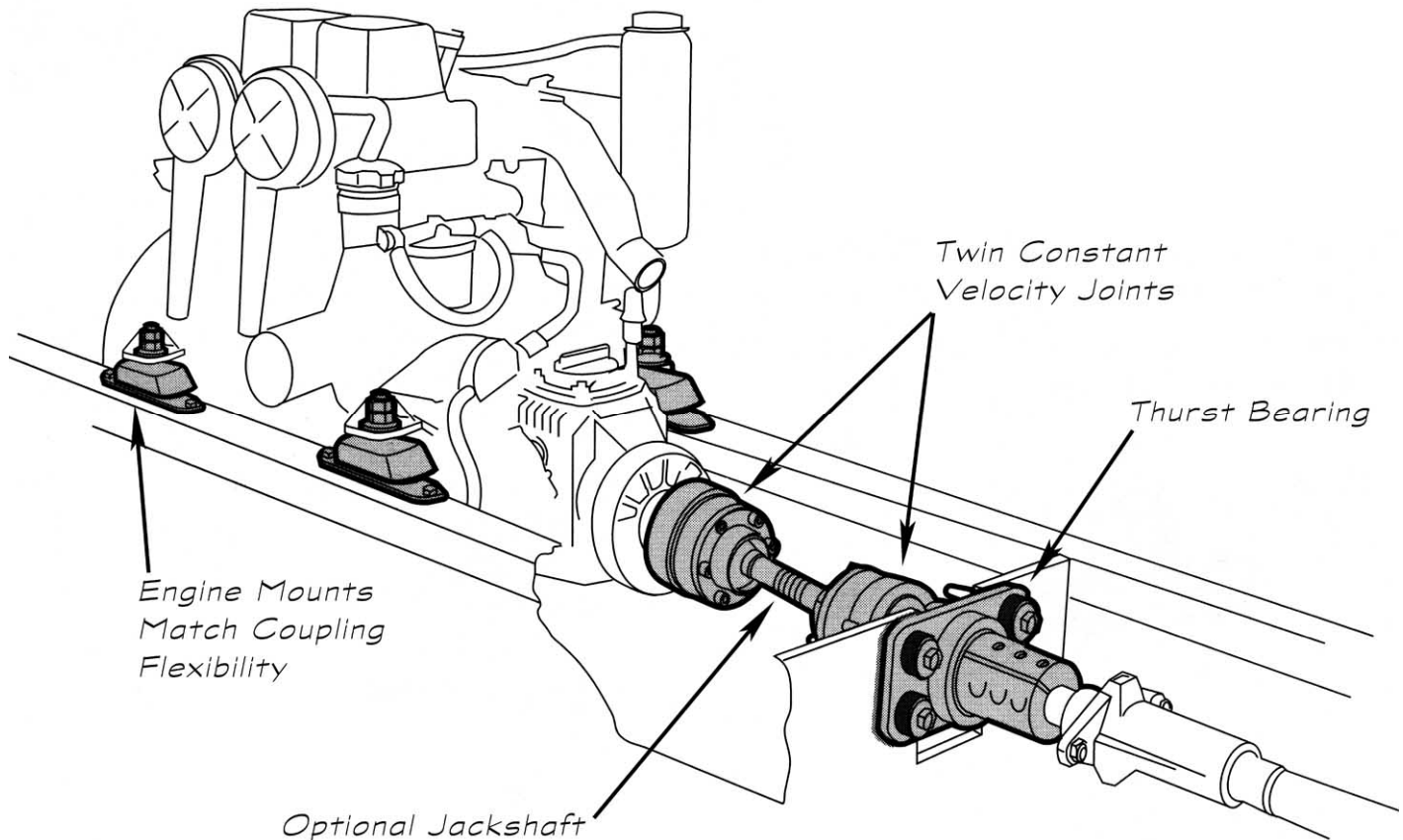

### Aquadrive Installation

Courtesy Aquadrive

moderately long shaft run inside the hull, you can usually retrofit it.

Now, if you've somehow managed to design and build your *Rickety Racket* with *all* these noise reduction methods, you'll have a boat so quiet it will truly qualify as a stealth machine. Get the paperwork out and have the name officially changed to *Stealthy Streak!*

### Sources For Noise Control Products

Soundown Corp. – [www.soundown.com](http://www.soundown.com)  
 Vetus den Ouden – [www.vetus.com](http://www.vetus.com)  
 Glacier Bay, Inc. – [www.glacierbay.com](http://www.glacierbay.com)  
 Halyard (Marine & Industrial) Limited – [www.halyard.eu.com](http://www.halyard.eu.com)  
 Technicon Industries, Inc. – [www.tcnind.com](http://www.tcnind.com)  
 Aquadrive – [www.aquadrive.net](http://www.aquadrive.net)  
 PYI, Inc. – [www.pyiinc.com](http://www.pyiinc.com)  
 Greenwood Forrest Products – [www.greenwoodproducts.com](http://www.greenwoodproducts.com)



**Santa Cruz Coastal Flyer, Dave Gerr design**